

[www.green.cz](http://www.green.cz)  
[www.parking-system.com](http://www.parking-system.com)



**Unattended Entry Fee Collection**  
**Bezobslužný výběr vstupného**

---

**Heavy Duty Mechanism, Robust Design, Long Lifetime**  
**Odolné robustní provedení s dlouhou životností**

---

**Anti-panic Folding Arms**  
**Sklopná ramena s funkcí Antipanic**

---

**Colour Display, Intuitive Operation**  
**Barevný displej s intuitivním ovládáním**

---

**One-way or Two-way Passage**  
**Jednosměrný nebo obousměrný průchod**

---

**Large Number of Accessories**  
**Velké množství příslušenství**

---

**COIN OPERATED TURNSTILE**  
**TURNIKET S POKLADNOU**

**GP4AT**

### BASIC INFORMATION

The coin operated turnstile is an integrated device that allows the movement of people when entering a chargeable zone of a building to be controlled. The combination of the two-way tripod turnstile and the automatic pay station allows the features of both devices to be used within a compact unit. The coin operated turnstile provides automated collection of single entry fees for entering a chargeable zone. Due to adjustable tariffs, different entry fees can be easily set for selected periods of time. After the payment has been made, the device issues a receipt to the customer. The receipt can be printed with a bar code or a QR code and then used e.g. as a discount voucher for further shopping. The coin operated turnstile works in fully autonomous mode, its operation does not require a connection to a master system. In some cases, however, the connection to a master system can be possible.

### FEATURES

- integration of the tripod turnstile and the automatic pay station
- control of access and passage of people to reserved areas
- automated collection of single entry fees when entering selected chargeable zones
- entirely autonomous operation (no connection to the server required)
- left-sided or right-sided version
- robust steel construction
- cabinet construction allowing easy access to internal components and handling of them (cash withdrawal, paper roll refill, etc.)
- electromotoric drive of the turnstile rotation
- folding arms
- coin validator allowing the automatic pay station to accept cash payments and return any overpayments in coins
- colour display showing visual instructions
- printer using direct thermal print for receipt printing

### PAYMENT PROCESS

- ① To control the device, the customer asking for access into a chargeable zone uses four buttons. Important information is shown on the integrated graphic display.
- ② After setting the passage relevant attributes (type of fee, multiple passages, etc.), the required amount is displayed.
- ③ The customer pays the fee in the required amount using coins.
- ④ After the financial amount has been accepted, a receipt is issued and any surplus amount is returned to the customer.
- ⑤ The device sends command to release the turnstile's rotation and the customer is allowed free passage into the zone.

### MAIN ADVANTAGES

- a possibility to use the receipt as a discount voucher
- adjustable tariffs for selected time specification (hours, days, holidays)
- adjustable one-way or two-way passage
- mechanical design resistant to physical damage
- quiet and smooth operation without bouncing
- design adjusted to intensive use
- *antipanic* - safety measure for emergency situations when arms are folded and free passage through the turnstile is possible
- intuitive user interface, easy to control
- long service life
- attractive design
- easy to install, maintain, undemanding to configure
- wall mount possible
- a possibility to use this equipment as a pay station with the connection to an indoor access device other than the turnstile

### SURFACE TREATMENT

The steel cabinet is zinc coated and this provides the product with long-term anti-corrosion resistance. The surface of the device is treated using polyester powder coating. The standard powder paints used for the coin operated turnstile are the following RAL colours:

- RAL 7043 - Traffic grey B,
- RAL 9006 - White aluminium.

### USE

The coin operated turnstile can be used in a variety of ways. The device is suitable both for private companies and public institution buildings. The coin operated turnstile can be installed in all buildings where automated collection of entry fees or fees for the use of services is required. The turnstile represents an ideal solution for example for:

- sanitary facilities (toilets, showers) at public places,
- transportation terminals (airports, railway stations, public transport terminals, etc.),
- petrol stations,
- restaurants and cafés,
- business and shopping centres,
- leisure and sports centres (sports stadiums, waterparks, swimming pools, etc.),
- historic sites and tourist attractions (funicular railways, museums, zoos, botanical gardens, etc.),
- accommodation and other types of buildings.

### OPTIONAL ACCESSORIES

- identification card reader
- external signalling
- gates
- handrails
- separating walls
- fixed barriers
- blocks
- other elements designed to control the movement of people

### OTHER PARAMETERS

Material	steel metal sheet of the 2 mm thickness
Dimensions without arms	400 × 310 × 1810 mm
Dimensions with arms	798 × 818 × 1810 mm
Arm height	894 mm
Weight	55 kg
Ingress protection	IP 40
Distribution network	TN-S (three-conductor line L, N, PE)
Power supply	230 V AC / 50 Hz
Power consumption in the idle state	30 W
Maximum power consumption	150 W
Working temperature	-25°C – +45°C
Accepted coins	up to 16 denominations
Returned coins	up to 6 denominations

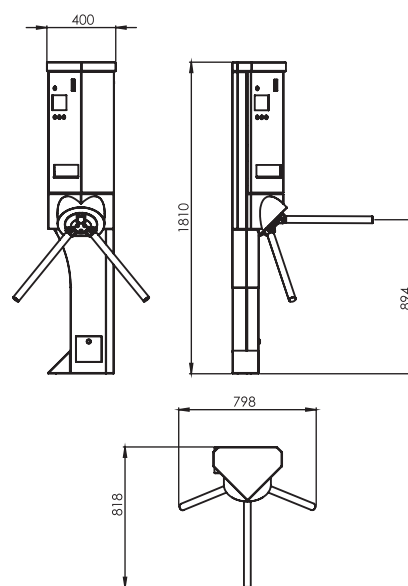

Modification of design and technical parameters reserved